

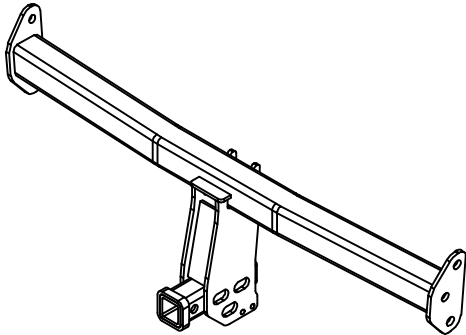

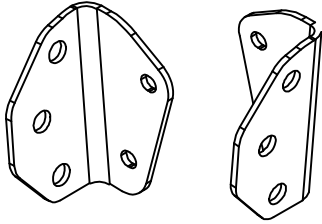

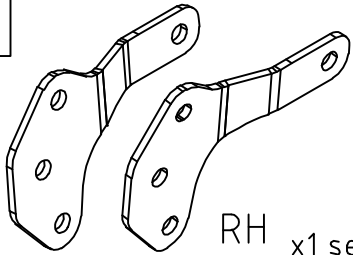

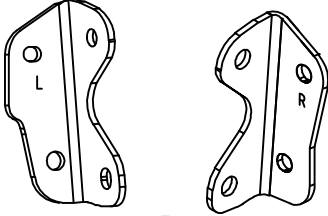

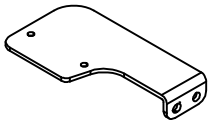
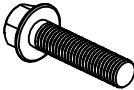

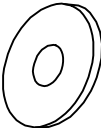

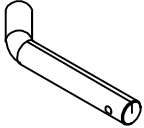
INSTALLATION  
INSTRUCTIONS

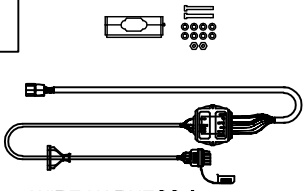
DESCRIPTION: 2015 OUTBACK  
TRAILER HITCH

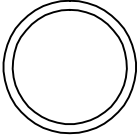
<p>A</p> <p>KIT CONTENTS :</p>  <p>x1</p>	<p>B</p>  <p>LH RH x1 set</p>			
<p>D</p>  <p>LH RH x1 set</p>	<p>E</p>  <p>LH RH x1 set</p>	<p>F</p>  <p>x1</p>		
<p>G</p>  <p><b>M12 HEX FLANGE HEAD BOLT (BLACK)</b> X10</p>	<p>H</p>  <p><b>M12 HEX FLANGE NUT (BLACK)</b> X4</p>	<p>I</p>  <p><b>M12 FLAT WASHER (SILVER)</b> X4</p>	<p>J</p>  <p><b>M10 HEX FLANGE NUT (BLACK)</b> X8</p>	<p>K</p>  <p><b>M6 HEX FLANGE HEAD BOLT (BLACK)</b> X2</p>
<p>L</p>  <p>x1</p>	<p>M</p>  <p>x1</p>	<p>N</p>  <p><b>WIRE HARNESS &amp; CONNECTOR HARDWARE KIT</b> X1</p>	<p>O</p>  <p><b>SELF-LOCKING EXHAUST NUT (SILVER)</b> X4</p>	<p>P</p>  <p><b>EXHAUST GASKET</b> X2</p>
<p>Q</p>  <p><b>FOIL TAPE 50mm x 150mm</b> X9</p>	<p>R</p>  <p><b>URETHANE TAPE</b> X1</p>	<p>S</p>  <p><b>RUBBER TRIM GASKET</b> X1</p>	<p>T</p>  <p>X1</p>	<p>U</p>  <p>x1</p>

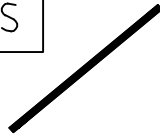
TOOLS REQUIRED:

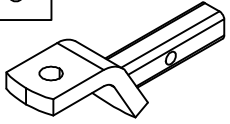
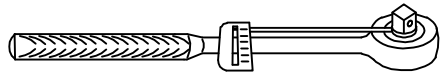

1/2" & 3/8" DRIVE TORQUE WRENCH

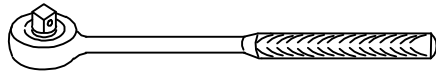

1/2" & 3/8" DRIVE RATCHET

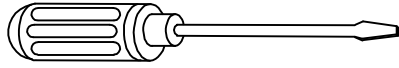

SLOT SCREWDRIVER

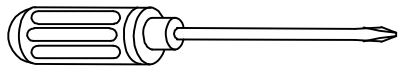

PHILLIPS SCREWDRIVER

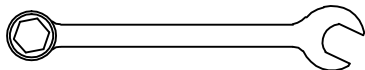

18 mm OPEN ENDED WRENCH

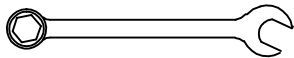

14 mm OPEN ENDED WRENCH

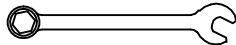

7 mm OPEN ENDED WRENCH

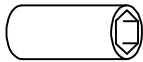

17 mm DEEP WELL SOCKET

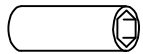

15 mm DEEP WELL SOCKET

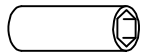

14 mm DEEP WELL SOCKET



10 mm SOCKET



7 mm SOCKET

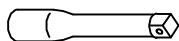

6" SOCKET EXTENSION

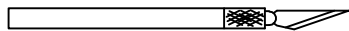

UTILITY KNIFE

CUTTING TOOL

NOTE: IF VEHICLE IS EQUIPPED WITH REAR BUMPER UNDERGUARD, REFER TO THE REAR BUMPER UNDERGUARD INSTRUCTIONS BEFORE BEGINNING THIS INSTALLATION PROCESS

# REAR TRAY, SPARE TIRE, RUBBER PLUG REMOVAL

## PREPARATION:

A.) WEAR SAFETY GLASSES.

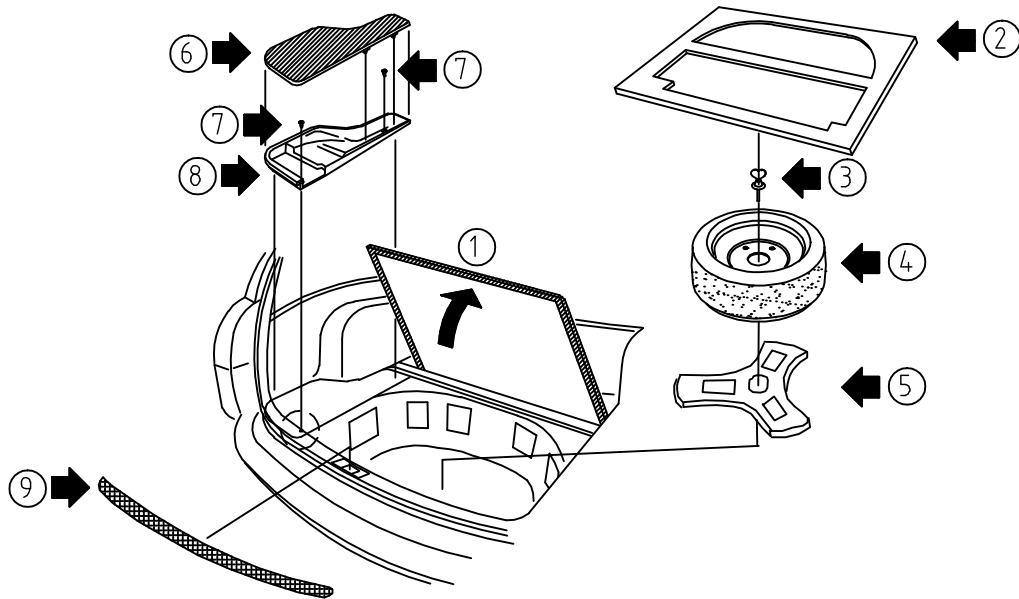

- 1.) RAISE AND REMOVE THE CARPETED SPARE TIRE COMPARTMENT COVER.
- 2.) REMOVE FOAM CENTER PANEL.
- 3.) UNSCREW AND REMOVE TIRE THUMBSCREW.
- 4.) REMOVE SPARE TIRE.
- 5.) REMOVE FOAM TRAY.
- 6.) REMOVE CARPETED LEFT HAND SIDE PANEL.
- 7.) REMOVE (2) PUSH PIN FASTENERS FROM LEFT HAND SIDE FOAM TRAY.
- 8.) REMOVE LEFT HAND FOAM TRAY.
- 9.) REMOVE REAR TAILGATE TRIM.
- 10.) REMOVE THE LEFT HAND TIRE WELL RUBBER PLUG.

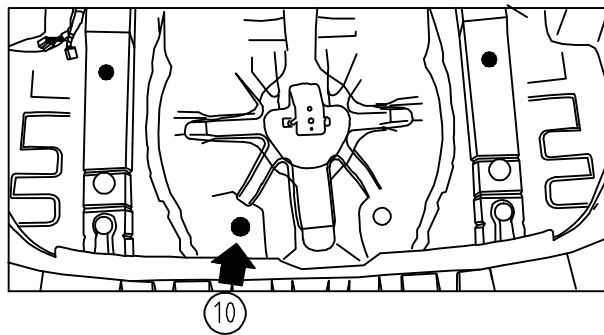

FRONT OF VEHICLE

## REMOVE REAR CARGO AREA COVER FOR WIRING HARNESS ROUTING AND INSTALLATION

1) FOLD DOWN REAR SEATS.

2) REMOVE CARPETED TRIM PIECE.

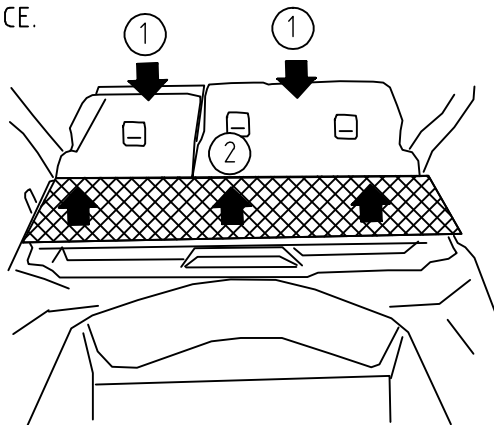

3) REMOVE (2) SEAT RELEASE CABLES FROM PLASTIC TRIM PIECE (#1).

4) REMOVE PLASTIC TRIM PIECE (#2).

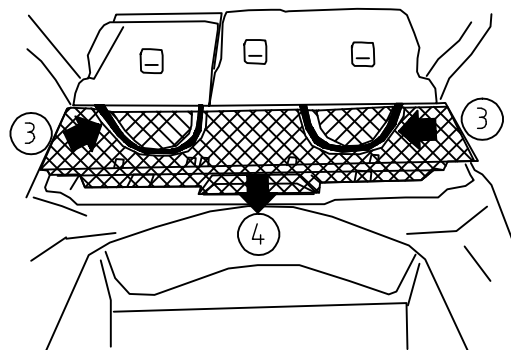

5) MAKE SURE THAT (6) BLUE PUSH-PINS AND ROUND GASKETS REMAIN INSTALLED ONTO PLASTIC TRIM PIECE TO ENSURE PROPER REINSTALLATION. SET ASIDE ALL PIECES AND PROTECT FROM DAMAGE. SAVE ALL PIECES FOR RE-INSTALLATION.

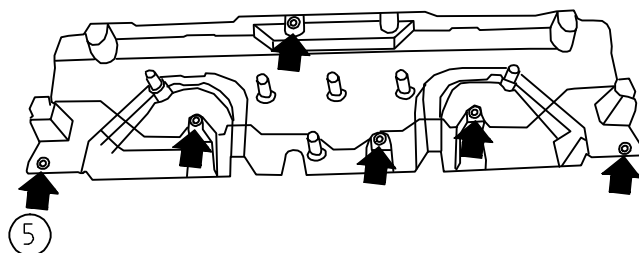

## REMOVE REAR TAIL LIGHTS

1) REMOVE TAIL LIGHT COVER (LEFT AND RIGHT SIDES) BY REMOVING (2) SCREW CLIPS.

2) USING 10MM SOCKET, REMOVE 2 BOLTS TO REMOVE TAIL LIGHT ASSEMBLY. REMOVE THE ASSEMBLY BY PULLING STRAIGHT BACK. (REPEAT FOR BOTH SIDES).

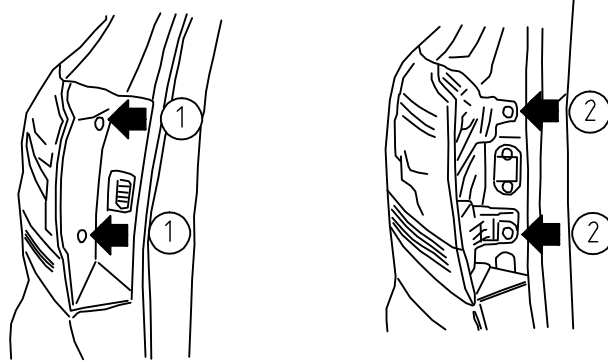

3) REMOVE SCREWS FROM BUMPER FASCIA. SCREWS CAN BE ACCESSED BY OPENING COVER. (REPEAT FOR OPPOSITE SIDE)

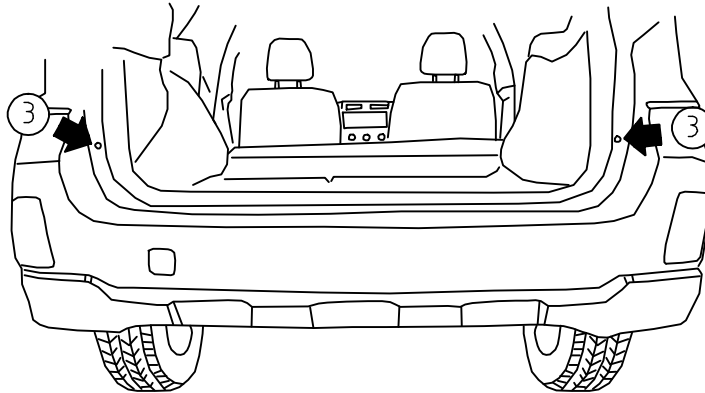

4) REMOVE (2) TAIL LIGHT BULBS AND (1) CONNECTOR FROM EACH SIDE.

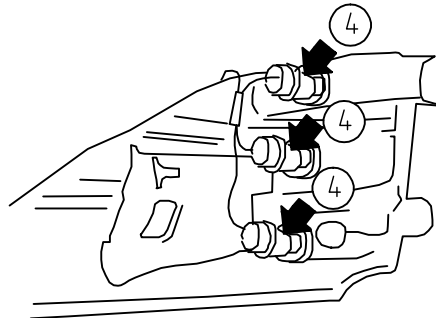

SET ALL PARTS ASIDE AND PROTECT FROM DAMAGE DURING BUMPER REMOVAL. PARTS WILL BE REINSTALLED LATER.

## REAR BUMPER FASCIA REMOVAL

- 1) WITH A SCREWDRIVER, RELEASE (1) SMALL PUSH BUTTON FASTENER PER SIDE ON THE LEFT AND RIGHT SIDE OF THE FASCIA WHEEL WELL. USE THE TIP OF THE SCREWDRIVER TO PUSH THE CENTER OF THE PIN IN.
- 2) WITH A SMALL FLAT HEAD SCREWDRIVER, REMOVE (7) LARGE PUSH PIN FASTENERS ACROSS THE LENGTH OF THE BUMPER.
- 3) STARTING AT THE LH SIDE REAR WHEEL, USING BOTH HANDS, PULL ONE SIDE OF THE FASCIA OUT FROM THE VEHICLE.
- 4) CONTINUE AROUND THE REAR LH SIDE. AT THE REAR CORNER, BEGIN TO PULL REARWARD AND WORK ACROSS THE VEHICLE FROM LEFT TO RIGHT TO REMOVE THE ENTIRE BUMPER.
- 5) FULLY RELEASE THE BUMPER FROM THE VEHICLE BODY.
- 6) LAY FASCIA ASIDE WHERE IT WILL NOT BE DAMAGED DURING HITCH INSTALLATION.

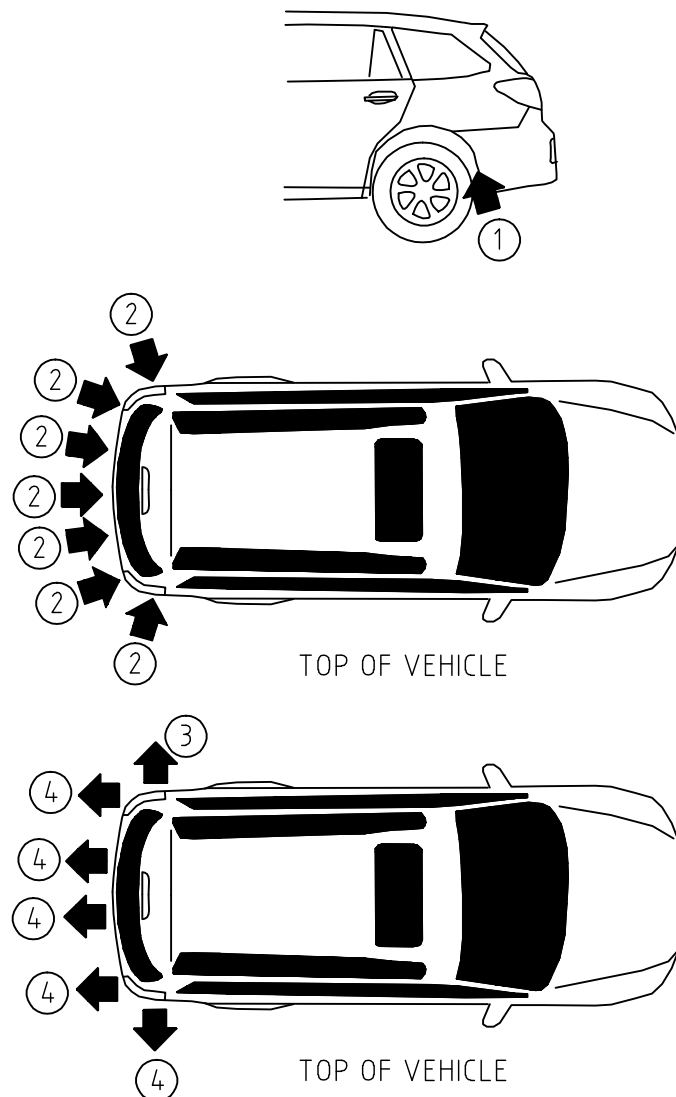

## MUFFLER(S) REMOVAL

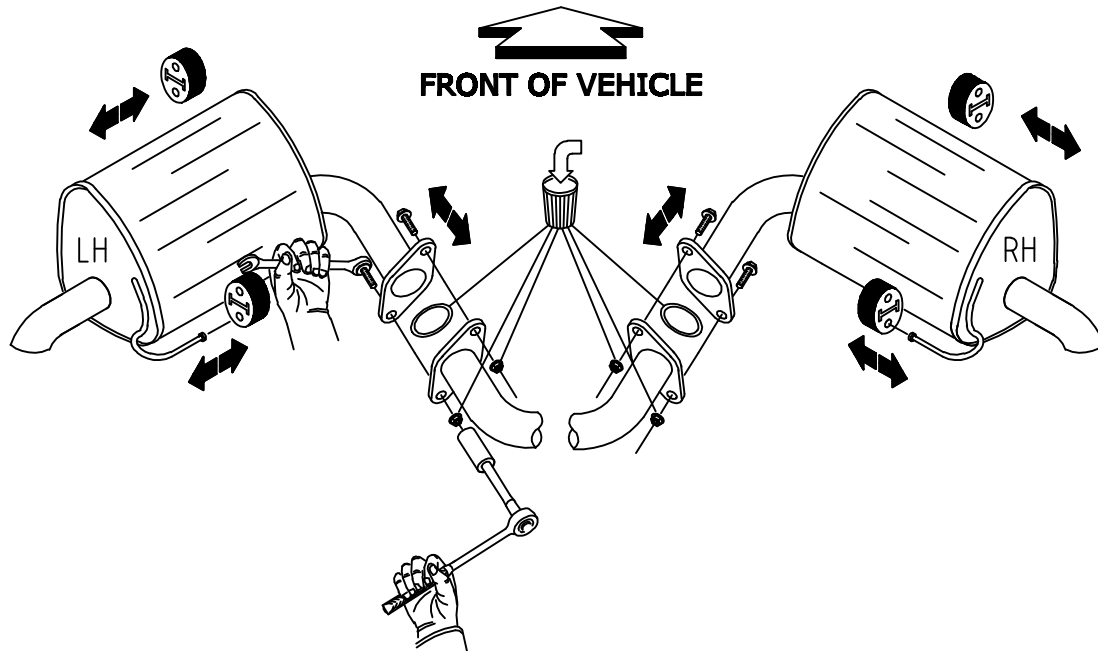

NOTE: 3.6L AND TURBO ENGINES HAVE 2 MUFFLERS THAT NEED REMOVAL  
2.5L ENGINE ONLY HAS 1 MUFFLER TO BE REMOVED

- 1) UNBOLT MUFFLERS FROM EXHAUST PIPES (4 LOCATIONS) WITH 14 MM OPEN END WRENCH AND SOCKET.
- 2) DISCARD THE (2) EXHAUST GASKETS AND (4) LOCK NUTS.
- 3) REMOVE MUFFLERS BY FIRST DISENGAGING THE REARMOST EXHAUST HANGER, THEN DISENGAGING THE FORWARDMOST EXHAUST HANGER.
- 4) PUT MUFFLERS ASIDE FOR LATER REINSTALLATION.

## HEAT SHIELD REMOVAL

- 1) REMOVE 4 HEAT SHIELD BOLTS AND THEN REMOVE HEAT SHIELD. RETAIN BOLTS AND HEAT SHIELD FOR RE-INSTALLATION.

NOTE: 3.6L AND TURBO ENGINES HAVE LH AND RH SIDE HEAT SHIELDS  
2.5L ENGINE ONLY HAS A LH HEAT SHIELD

- 2) REMOVE (2) RUBBER GROMMETS FROM EACH SIDE OF FRAME RAIL, ONE IS ON THE OUTSIDE AND THE OTHER IS ON THE BOTTOM OF THE FRAME RAIL.

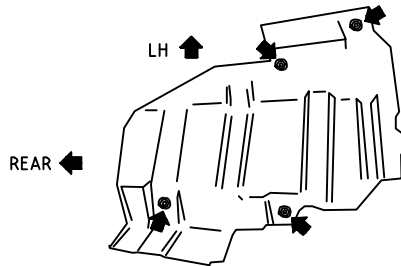

(LH SIDE PART FROM  
UNDERSIDE OF VEHICLE)

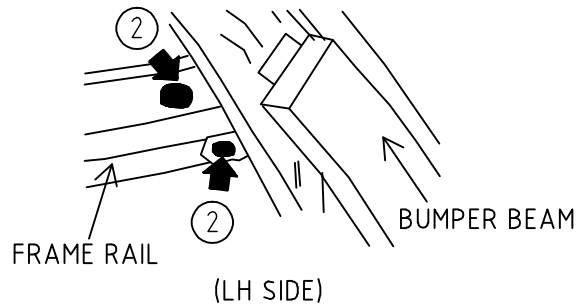

## REMOVE BUMPER BEAM

- 1) REMOVE AND DISCARD FOAM PIECE.
- 2) REMOVE (4) BUMPER BEAM NUTS FROM THE STUD BOLTS ON THE END OF THE FRAME. THE TOP BOLTS CAN BE ACCESSED THROUGH TOOLING HOLES IN BUMPER BEAM.  
NOTE: HOLD THE BUMPER BEAM WITH ONE HAND WHILE TAKING OFF THE LAST NUT SO IT DOES NOT FALL IN THE PROCESS.
- 3) DISCARD THE NUTS.
- 4) REMOVE THE BUMPER BEAM AND DISCARD.

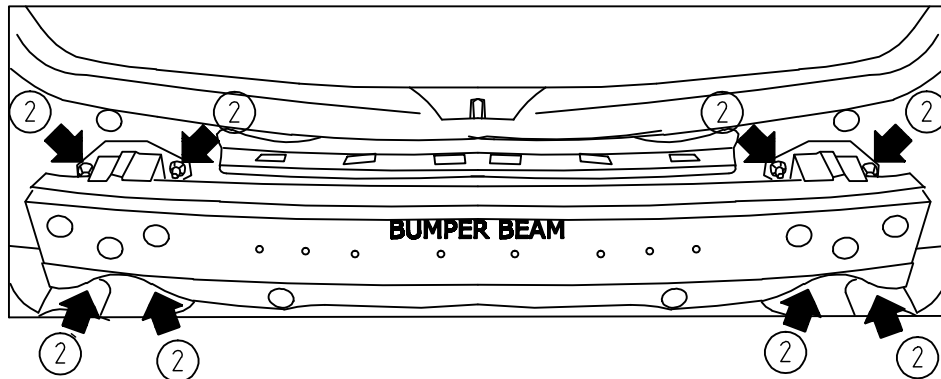



## INSTALL RIGHT HAND / LEFT HAND PARTS "C" & "D" AND PARTS "B" & "E"

1) PLACE LEFT HAND WELDED BRACKET SUBASSEMBLY "C" AND BRACKET "D" INTO SIDE FRAME RAIL OPENING.

2) ALIGN THE BRACKET HOLES WITH THE HOLES IN THE FRAME RAIL AND INSTALL BOLT "G" AND FLAT WASHER "I" THROUGH THE FRAME RAIL AND INTO THE BRACKETS IN 2 LOCATIONS.

3) DO NOT TIGHTEN THE BOLTS IN ORDER TO ALLOW CROSS CAR ADJUSTMENT IN LATER STEPS.

REPEAT STEPS 1-3 FOR THE RH SIDE.

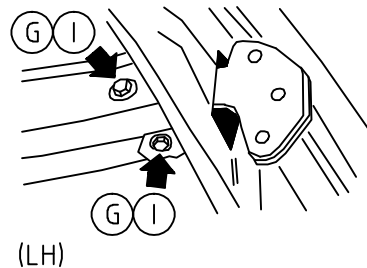
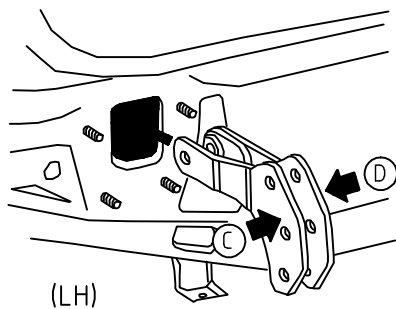

4) PLACE BRACKETS "B" AND "E" ONTO THE BUMPER BEAM BOLTS.

5) LOOSELY INSTALL 4 FLANGE NUTS "J" ONTO THE BUMPER BEAM BOLTS.

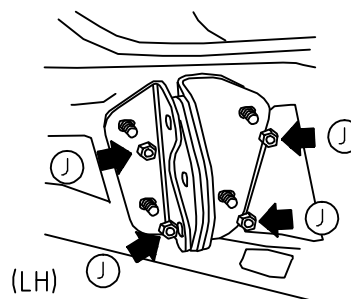
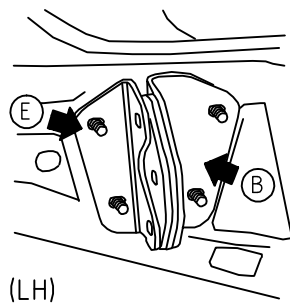

6) REPEAT STEPS 4-5 FOR THE RIGHT HAND SIDE PARTS.

## INSTALL MAIN HITCH "A"

- 1) INSTALL MAIN HITCH "A" BETWEEN THE LH AND RH BRACKET SETS.

POSITION THE HITCH "A" JUST ABOVE THE BRACKETS AND SLOWLY SLIDE IT DOWN BETWEEN BRACKETS AND INTO POSITION.

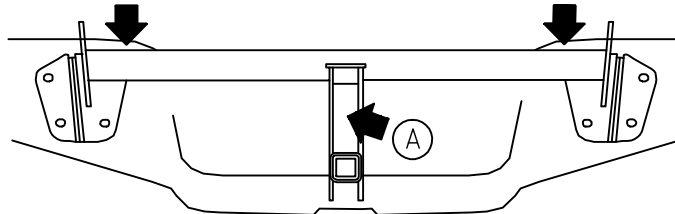

- 2) INSTALL 2 BOLT "G" INTO THE TOP AND BOTTOM HOLES ON THE LH SIDE THROUGH ALL PIECES (A,B,C,D AND E).

NOTE: BOLT CAN BE INSTALLED FROM OPPOSITE SIDE AS SHOWN IF TORQUE TOOLING ACCESS IS AN ISSUE (REFERENCE PG 11, STEP #2).

- 3) REPEAT STEP 2 FOR THE RH SIDE.
- 4) LOOSELY INSTALL NUT "H" ONTO THE 4 BOLTS INSTALLED IN STEPS 2 AND 3.
- 5) INSTALL 1 BOLT "G" THROUGH THE CENTER HOLE AND INTO THE NUT INSIDE THE HITCH BRACKET.
- 6) REPEAT FOR THE OTHER SIDE.

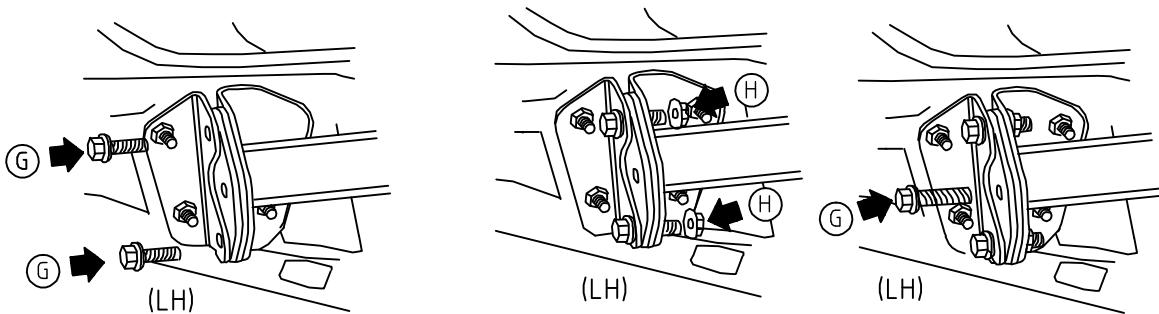

- 7) HAND TIGHTEN ALL 12 NUTS.  
(8 NUTS "J" FROM PAGE 9, STEP 5 AND 4 NUTS "H" FROM PAGE 10, STEP 4)

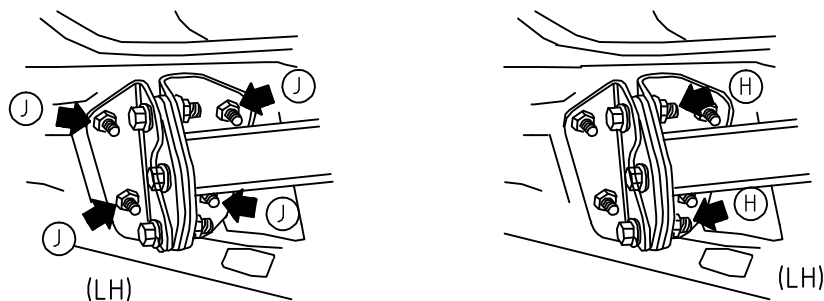

# TORQUE FASTENERS

1) TORQUE ALL FASTENERS IN THE ORDER AND TO THE TORQUE REQUIREMENTS AS SHOWN IN THE TABLE.

ORDER	TORQUE (Nm)	TORQUE (ft-lb)	SOCKET SIZE (mm)
1	95	70	17
2	95	70	17
3	95	70	17
4	95	70	17
5	70	51	15
6	70	51	15
7	70	51	15
8	70	51	15
9	70	51	15
10	70	51	15
11	70	51	15
12	70	51	15
13	95	70	17 & 18mm WRENCH
14	95	70	17 & 18mm WRENCH
15	95	70	17 & 18mm WRENCH
16	95	70	17 & 18mm WRENCH
17	95	70	17
18	95	70	17

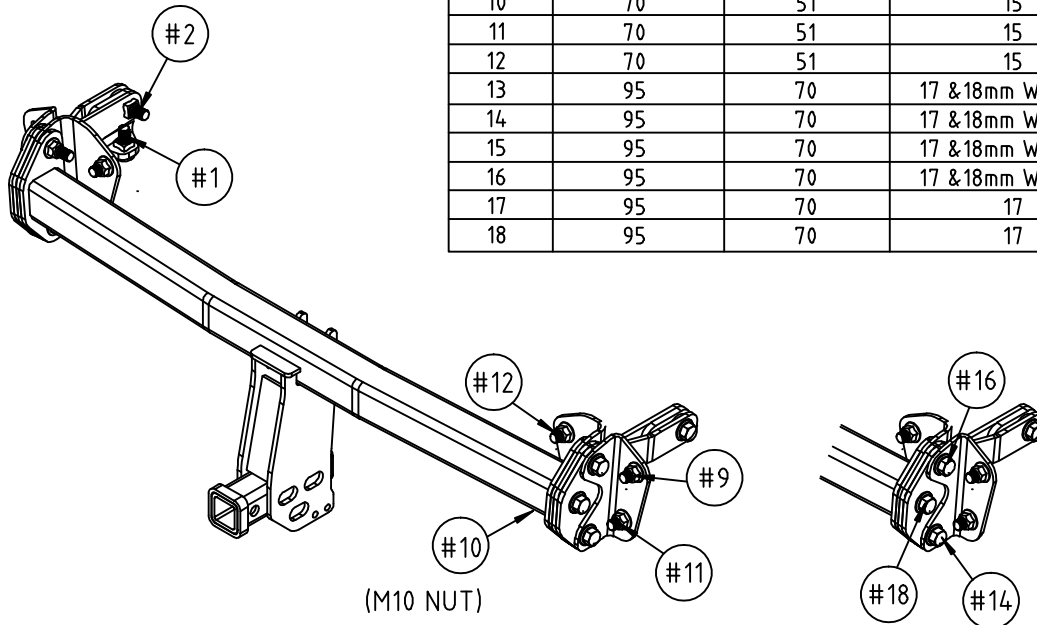

2) NOTE: FOR BOLTS #13-16 ONLY IF IT IS DIFFICULT TO GAIN PROPER TOOLING ENGAGEMENT WITH THE TORQUE WRENCH, THE INSTALLATION DIRECTION OF THE BOLTS/NUTS CAN BE REVERSED TO ALLOW BETTER ACCESS.

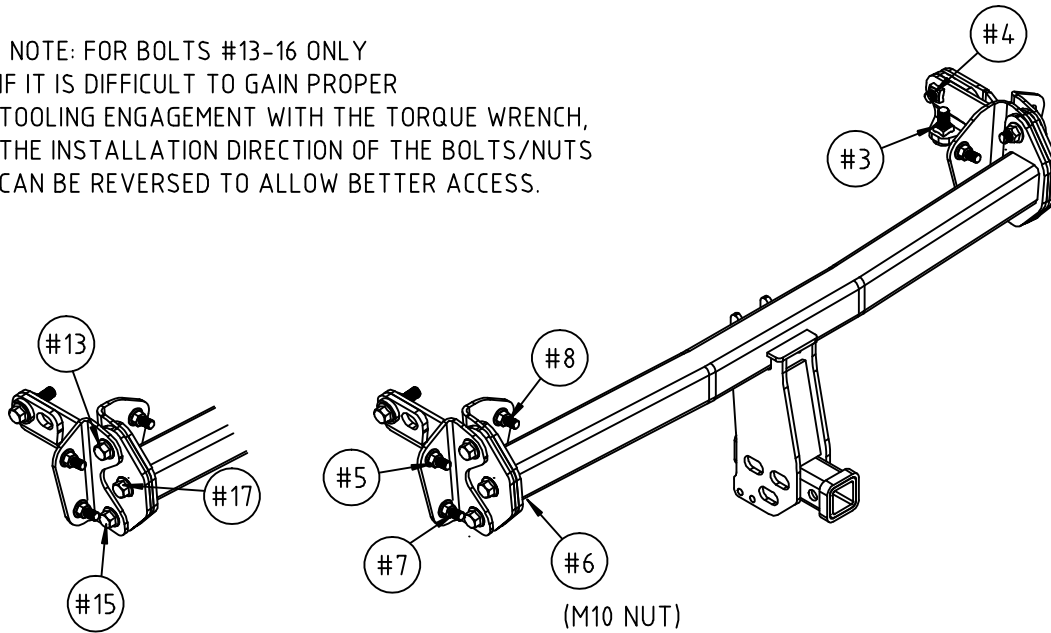

## MODIFYING THE REAR BUMPER FASCIA

MOVE THE FASCIA TO A FLAT AREA IN ORDER TO CUT THE "U" SHAPE OUT FOR THE TRAILER HITCH.

LOOK INSIDE AT THE CENTER BOTTOM FOR A "U" SHAPE SCRIBED PATTERN LINE FOR THE HITCH THAT WILL BE USED AS A GUIDE TO CUT THE FASCIA.

- 1.) CAREFULLY CUT OUT THE FASCIA ALONG THE LINE.
- 2.) REMOVE ALL BURRS AND ROUGH EDGES AFTER THE CUT IS MADE.

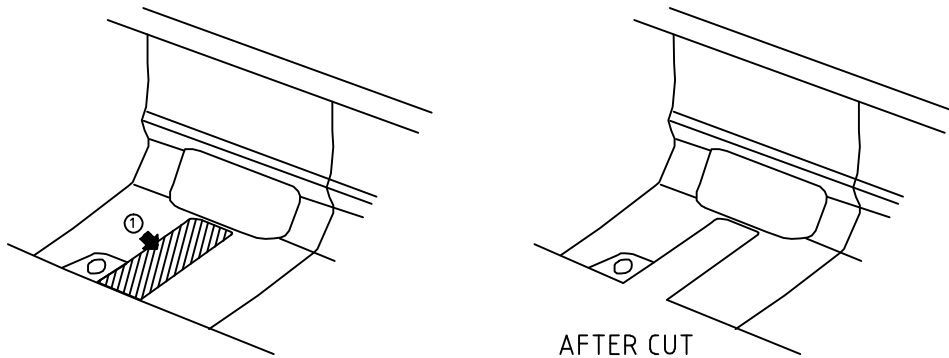

## INSTALL RUBBER TRIM GASKET

- 1.) MAKE SURE THE STARTING END HAS A 90° EDGE.
- 2.) STARTING AT THE END OF THE OPENING, CAREFULLY SLIDE THE GASKET "S" ALONG THE CUT EDGE.
- 3.) CONTINUE TO WRAP AROUND THE OPENING, BEING SURE TO CREATE A SMOOTH JOINT AS YOU GO.
- 4.) ONCE GASKET IS IN PLACE, TRIM EXCESS LENGTH SO THAT IT IS EVEN WITH THE EDGE.

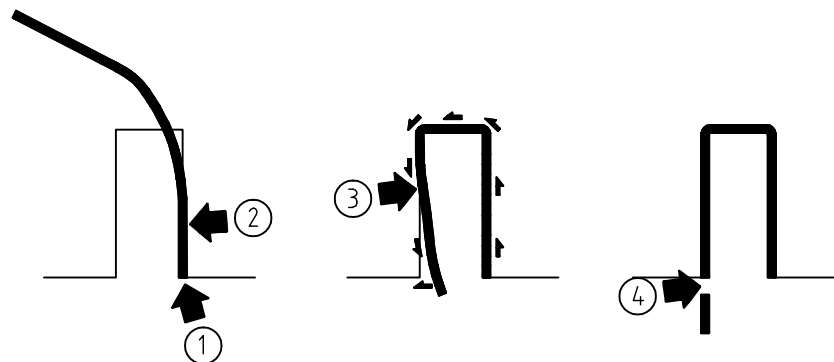

## WIRING HARNESS PRE-CONNECTOR PREPARATION

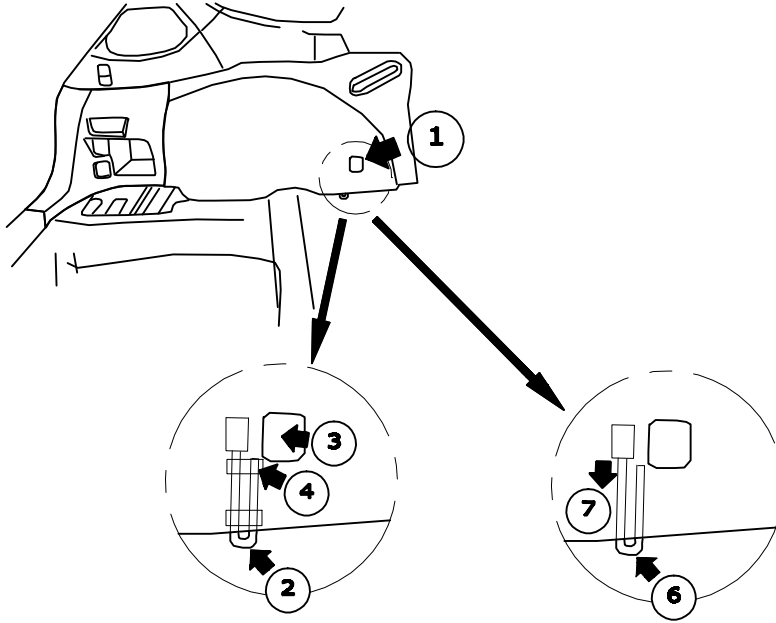

1.) REMOVE THE LUGGAGE HOOK AT THE FRONT OF THE LH TRUNK TRIM PIECE. IN ORDER TO GAIN ACCESS TO THE WIRING HARNESS PRE-ARRANGED CONNECTOR.

2.) FIND THE LOOPED WIRING HARNESS PRE-ARRANGED CONNECTOR UNDER THE TRIM PIECE AND CUT THE TAPE HOLDING THE "U" SHAPED LOOP TOGETHER. BE CAREFUL NOT TO CUT THE WIRING.

3.) REACH THROUGH THE LUGGAGE HOOK HOLE AND FIND THE CONNECTOR END OF THE WIRING HARNESS. IT WILL BE LOCATED JUST TO THE REARWARD SIDE OF THE HOLE.

4.) PULL THE HARNESS CONNECTOR THROUGH THE HOLE AND REMOVE THE TAPE.

5.) PUSH THE CONNECTOR BACK INTO THE HOLE AND BEHIND THE TRIM PANEL.

6.) RETURN TO THE WIRING LOOP AT THE BOTTOM OF THE TRIM PIECE (FROM STEP 2).

7.) PULL THE CONNECTOR END OF THE HARNESS OUT UNDER THE TRIM PIECE.

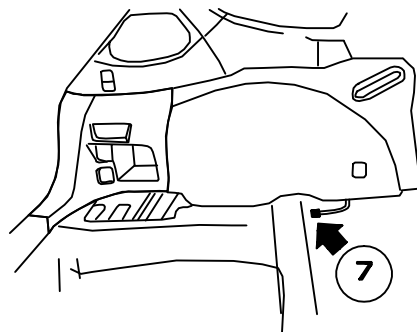

## PART "N" INSTALLATION & ROUTING

1.) REMOVE THE OUTSIDE GRILL PANEL FROM THE REAR LH SIDE. RELEASE THE (3) TOP AND (3) BOTTOM CLIPS FROM THE INSIDE OF THE VEHICLE TO PREVENT DAMAGE

2.) PLUG THE TOW HITCH WIRING HARNESS "N" INTO THE END OF THE PRE-CONNECTOR.

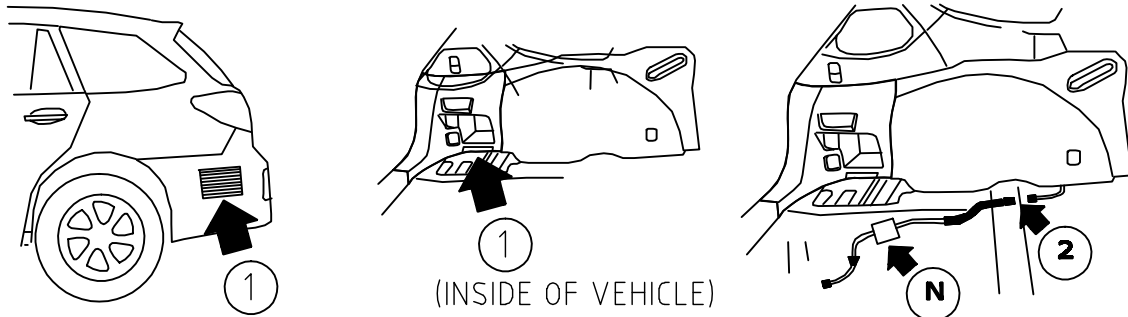

3) WRAP THE EXPOSED AREA OF THE CONNECTOR INTERFACE WITH URETHANE TAPE "R" FOR NOISE AND VIBRATION REDUCTION. THEN ROUTE THE WIRING HARNESS AS SHOWN BELOW.

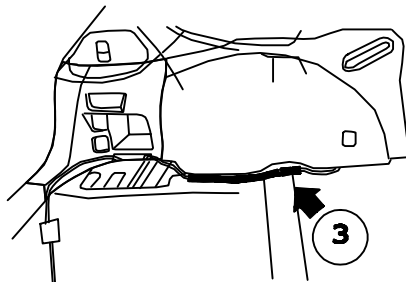

4.) USE ALUMINUM FOIL TAPE "Q" TO SECURE THE WIRING TO THE VEHICLE IN THE 7 LOCATIONS AS SHOWN. ONLY APPLY TAPE TO METAL SURFACES. TUCK TAPE UNDER PLASTIC TRIM AS NEEDED.

5.) ACCESS THE WIRING HARNESS FROM THE OUTSIDE TO TAPE IN THE AREA LABELED "5".

6.) TUCK THE PORTION OF THE HARNESS WITH THE FOAM TAPE UNDER THE SIDE TRIM PIECE.

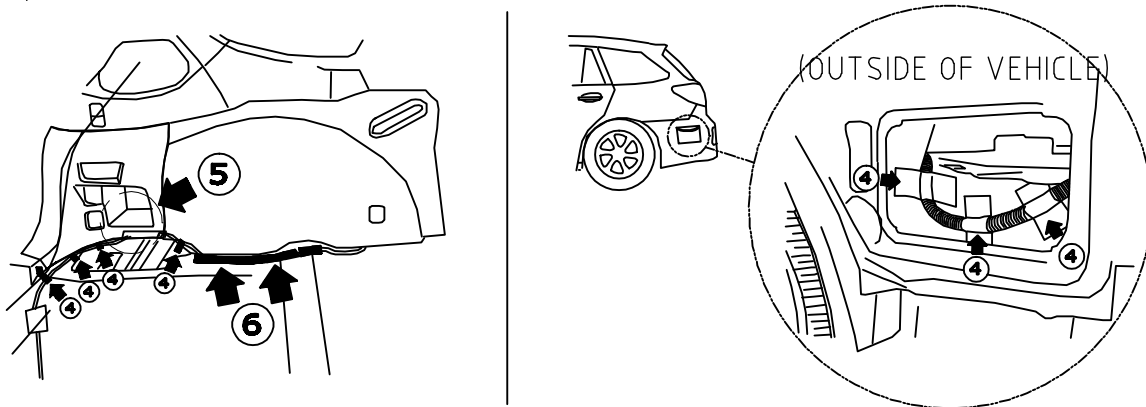

## PART "N" INSTALLATION & ROUTING (CONTINUED)

1.) ROUTE THE 4 PIN CONNECTOR END OF THE WIRE HARNESS INTO THE HOLE IN THE SPARE TIRE COMPARTMENT AND INSTALL THE RUBBER GROMMET INTO THE HOLE.

2.) VERIFY THAT THE INSIDE WALL IN THE SPARE TIRE AREA IS CLEAN. PEEL BACKING OFF THE DOUBLE SIDED TAPE ON THE POWER CONVERTER AND FUSE HOLDER AND PRESS ONTO THE REAR LEFT HAND SIDE OF THE SPARE TIRE AREA AS SHOWN. MAKE SURE THAT THE CONVERTER AND FUSE HOLDER ARE PRESSED FIRMLY ONTO THE FLAT INNER WALL OF THE SPARE TIRE AREA.

3.) APPLY 2 PIECES OF TAPE TO SECURE THE WIRE HARNESS TO THE INSIDE WALL OF THE SPARE TIRE WELL IN THE LOCATIONS AS SHOWN.

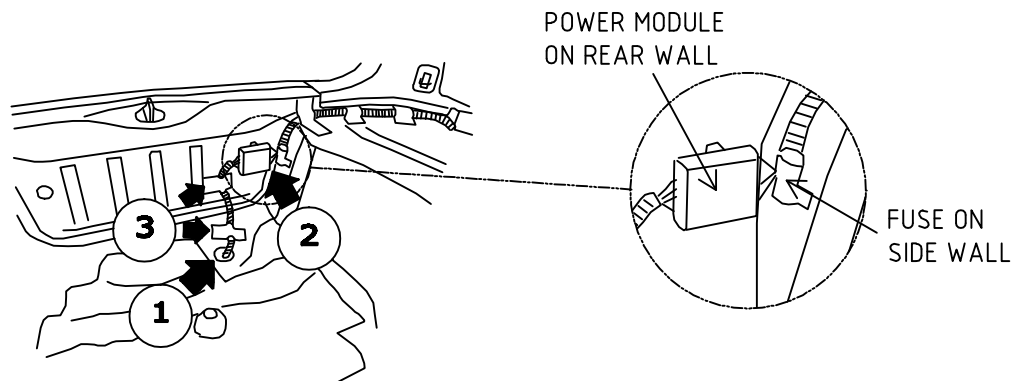

## WIRING HARNESS CONNECTOR & BRACKET INSTALLATION

1.) INSTALL 4-PIN CONNECTOR INTO WIRING HARNESS MOUNTING BRACKET "F" USING THE CLAMP BRACKET AND HARDWARE INCLUDED WITH THE WIRING HARNESS. TORQUE THE BOLTS TO  $1.7 \pm 0.3$  Nm ( $15 \pm 3$  in-lb).

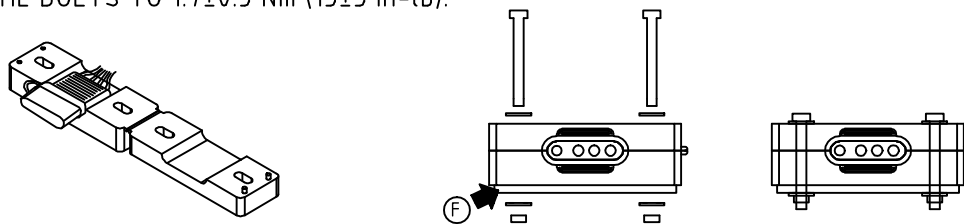

2.) INSTALL WIRING HARNESS MOUNTING BRACKET "F" (WITH 4-PIN CONNECTOR) ONTO THE CENTER OF THE HITCH ASSEMBLY "A" USING 2 BOLTS "K".

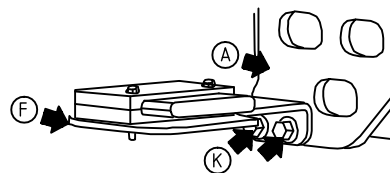

3.) TORQUE THE 2 BOLTS TO  $15 \pm 3$  Nm ( $11 \pm 2$  ft-lb).

## REINSTALLATION OF COMPONENTS

- 1.) REINSTALL LH SIDE GRILL PANEL.
  - 2.) REINSTALL HEAT SHIELD(S). TORQUE TO 10 Nm (90 in-lb).
  - 3.) REINSTALL THE MUFFLERS USING THE SELF LOCKING NUTS ("O") AND THE EXHAUST GASKETS ("P") SUPPLIED. TORQUE THE EXHAUST NUTS TO  $48\pm5$  Nm ( $35\pm4$  ft-lb).
- NOTE: SINGLE EXHAUST WILL USE 2 NUTS AND 1 GASKET, DUAL EXHAUST WILL USE 4 NUTS AND 2 GASKETS.
- 4.) REINSTALL REAR BUMPER FASCIA.
  - 5.) REINSTALL REAR TAIL LIGHT BULBS INTO TAIL LIGHT HOUSING ASSEMBLIES.
  - 6.) REINSTALL REAR TAIL LIGHT ASSEMBLIES. TORQUE TO 7 Nm (5 ft-lb).
  - 7.) REINSTALL REAR TAIL LIGHT COVERS.
  - 8.) REINSTALL (2) SEAT RELEASE CABLES INTO TRIM PIECE BEHIND REAR SEATS.
  - 9.) REINSTALL CARPETED COVER TRIM PIECE BEHIND REAR SEATS.
  - 10.) REINSTALL SPARE TIRE AND RELATED COMPONENTS.
  - 11.) PLACE HITCH BALL ATTACHMENT "U" UNDER CARGO FLOOR.
  - 11.) REPLACE REAR COMPARTMENT COVER.

## ADDITIONAL NOTES:

- 1.) FOR FURTHER INFORMATION, READ VEHICLE'S OWNERS MANUAL OR CONSULT YOUR DEALER OR DEALER'S SERVICE DEPARTMENT.
- 2.) AFTER TRAILER HITCH HAS BEEN IN USE FOR ~600 MILES, RETIGHTEN ALL MOUNTING BOLTS. (OBSERVE CORRECT TIGHTENING TORQUE PER PAGE 11).
- 3) DO NOT USE OIL OR GREASE ON BOLT/NUT MOUNTING LOCATIONS.
- 4) SUBARU ACCEPTS NO LIABILITY FOR PRODUCT DEFECTS CAUSED BY THE VEHICLE OWNER OR OTHER PERSONS AND/OR INCORRECT USE.